

Manual de instalação ALT-ST20

Prepare a frente do armário

No lado do armário onde serão fixadas as dobradiças adicione um acabamento para minimizar a visibilidade das ferragens e para garantir que as frestas de ambos os lados da porta sejam simétricas.

As medidas dos painéis esquerdo e direito são diferentes.

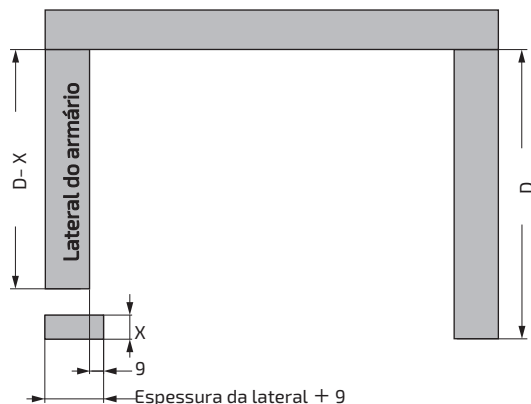

D = Profundidade
X = Espessura máx. da porta - 14

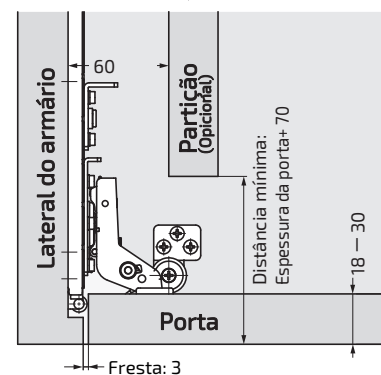
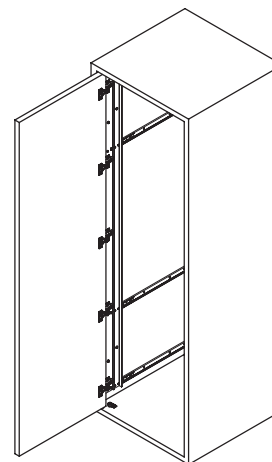

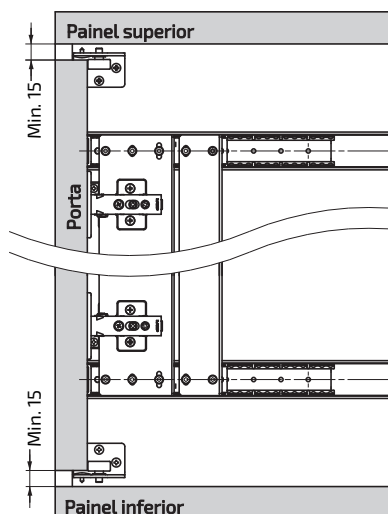

Preparando a porta

- Largura da porta = Largura de abertura do armário - 15
onde 15 mm = 9 (Largura do acabamento) + 3 (Fresta esquerda) + 3 (Fresta direita)
- Altura da porta = Altura da abertura do armário 10
onde 10mm = 5 (Fresta superior) + 5 (Fresta Inferior)



Tamanho da corredeira	Profundidade para recolhimento da porta	Profundidade do móvel
488	345 + Espessura da porta	488 + Espessura da porta
564	421 + Espessura da porta	564 + Espessura da porta
615	472 + Espessura da porta	615 + Espessura da porta
717	574 + Espessura da porta	717 + Espessura da porta

		Sistema ALT-ST20			
		S	M	L	LL
1	Corrediça* 	2	3	4	4
2	Placa sincronizadora 	1	1	1	1
3	Placa de União 	1	1	1	1
4	Dobradiça Olympia Amortecida 	2	3	4	5
5	Calço da dobradiça 	2	3	4	5
6	Placa de montagem 	2	3	4	5
7	Rolete guia 	2	3	3	3
8	Trava** 	2	2	3	3
9	Roldana 	2	2	2	2
10	Par de Engates da roldana 	1	1	1	1
		1	1	1	1
11	Bucha 	2	2	2	2
12	Suporte de deslizamento 	2	2	2	2
13	Parafuso de regulagem 	1	2	2	2
14	Parafuso cab. flangeada 3.5x15 	18	27	34	34
15	Parafuso cab. flangeada 4x16 	6	6	6	6
16	Parafuso cab. panela 3.5x15 	4	6	8	10
17	Parafuso M4x6 	10	15	20	20
18	Parafuso cab. panela M4x10 	6	9	12	15
19	Chave Allen 	1	1	1	1

- *Não corte as corrediças. Os tamanhos de corrediça (mm) são 488, 564, 615 e 717.
- **Esta trava segura a porta na posição puxada para fora. Certifique-se de fixá-la nas corrediças superior e inferior. (Para detalhes, veja pág 4).

1 Montagem das roldanas no armário (painéis superior e inferior) - Existem duas opções de montagem:

Montagem sobreposta

■ Use o engate da roldana ⑩

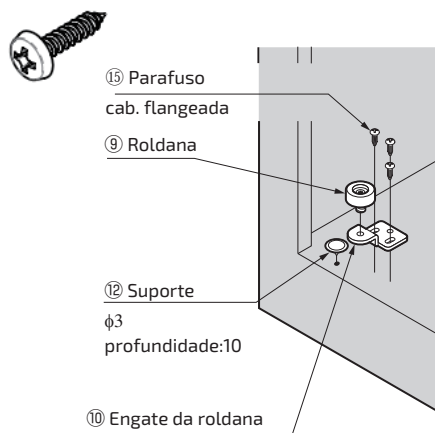

Para engate de roldana

Vista superior do armário

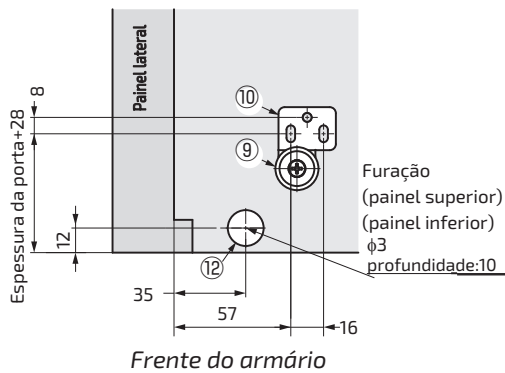

Montagem embutida

■ Use a bucha ⑪

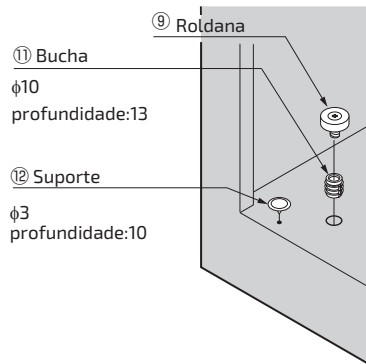

Para bucha

Vista superior do armário

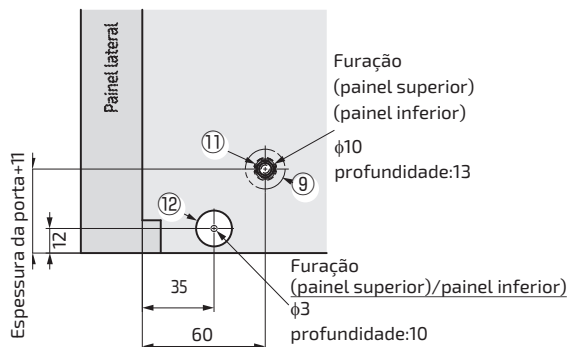

2 Instale as trava nas corredeiras

Instalação da trava

Sinal de direção para frente ◀

Remova 1

Trava

Insira 2

Modelo	S	M	L	LL
Quantidade Corredeiras	2	3	4	4
Quantidade Travas	2	2	3	3
Localização das Travas				
[■ trava]				

Veja a próxima página para o posicionamento das corredeiras

3 Instale as corredeiras e os roletes guias (fixe com todos parafusos apenas a corredeira da parte superior e os demais de forma temporária)

1 Fixe a corredeira superior no lugar com os parafusos fornecidos. Parafusos: Parafuso cab. flangeada 3.5x15

2 Fixe temporariamente as demais corredeiras apenas com o parafuso frontal e traseiro.

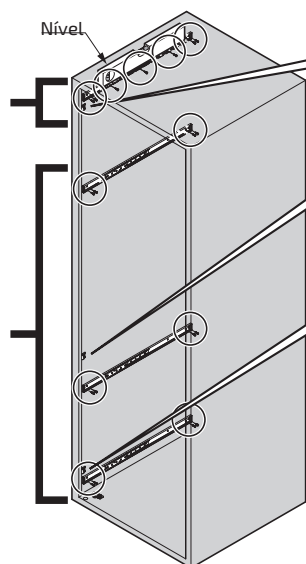

3 Monte o rolete guia

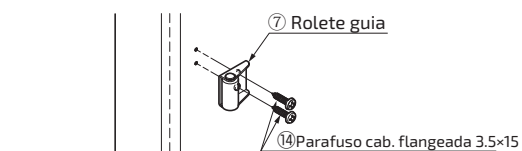

Cuidado
posicionado para não interferir nas corredeiras

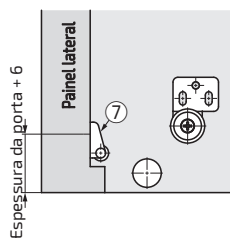

Tipo S (2 corredeiras) Posição das corredeiras

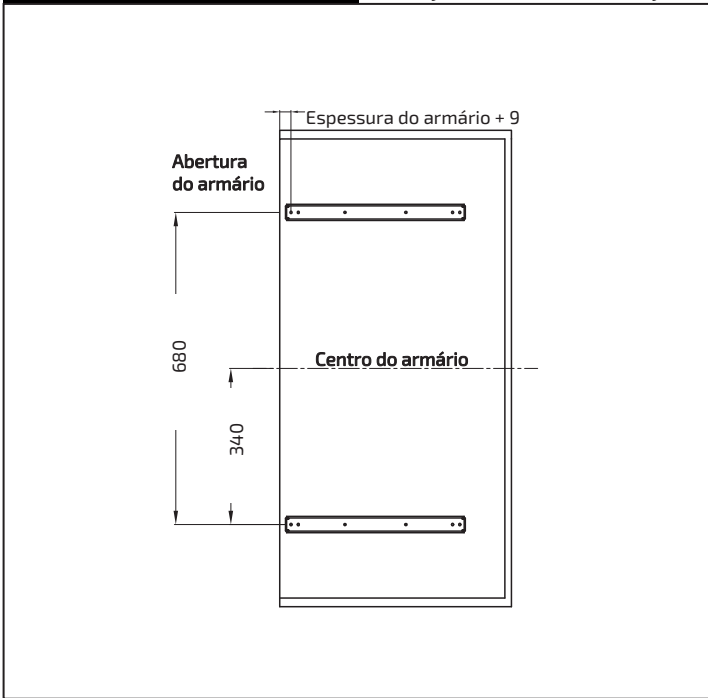

Tipo M (3 corredeiras) Posição das corredeiras

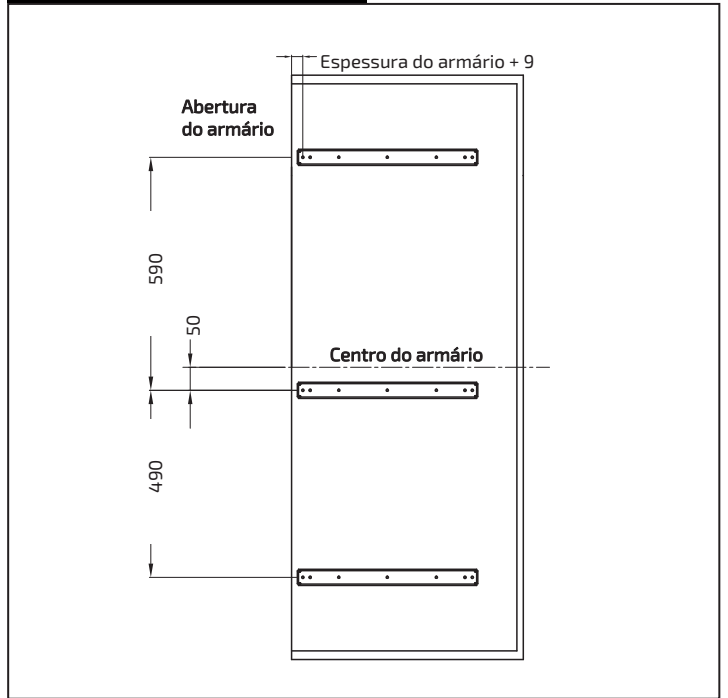

Tipo L (4 corredeiras) Posição das corredeiras

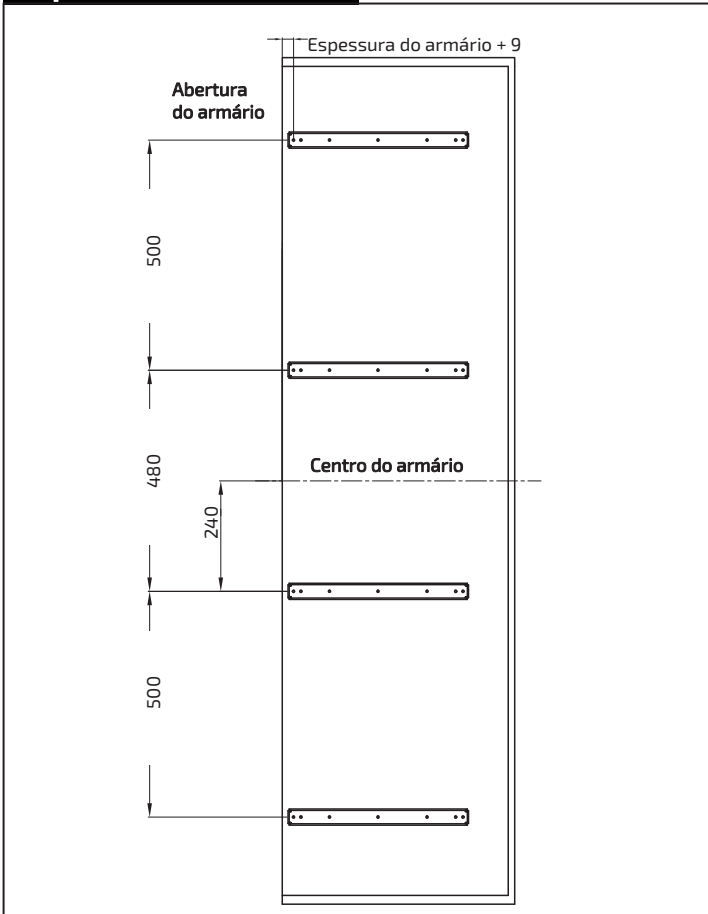

Tipo LL (4 corredeiras) Posição das corredeiras

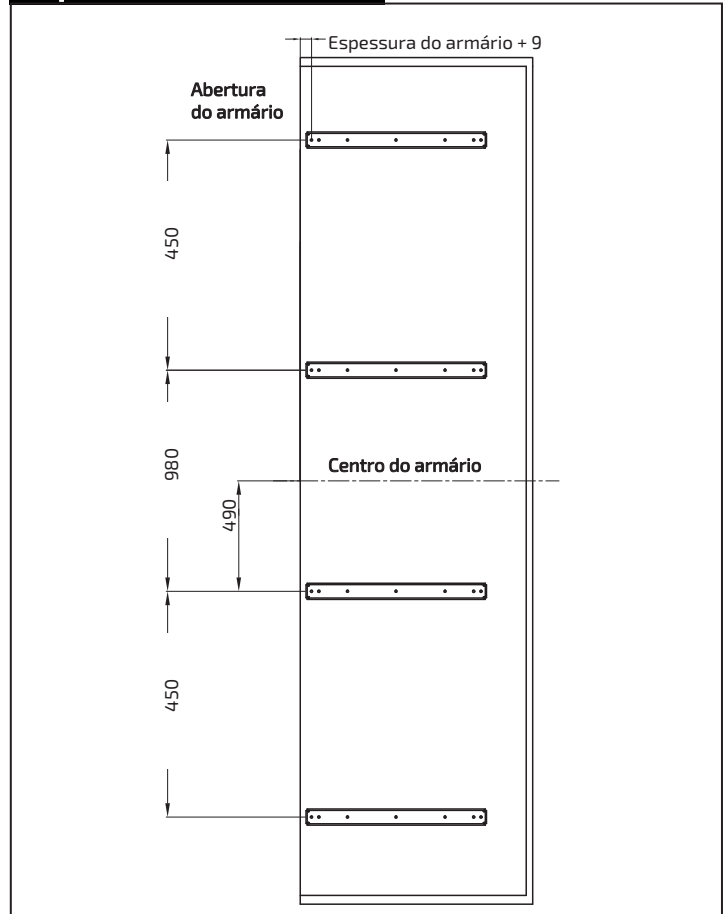

5 Anexe a placas de montagem e o calço à barra de conexão

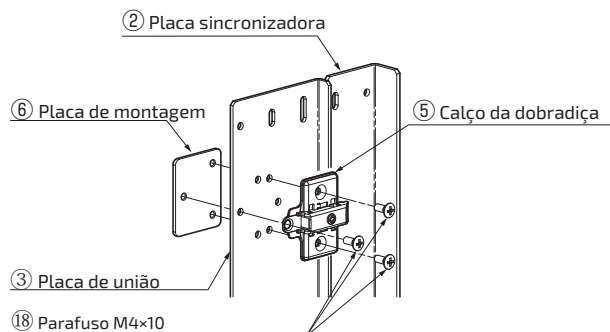

6 Monte a barra de conexão nas corrediças

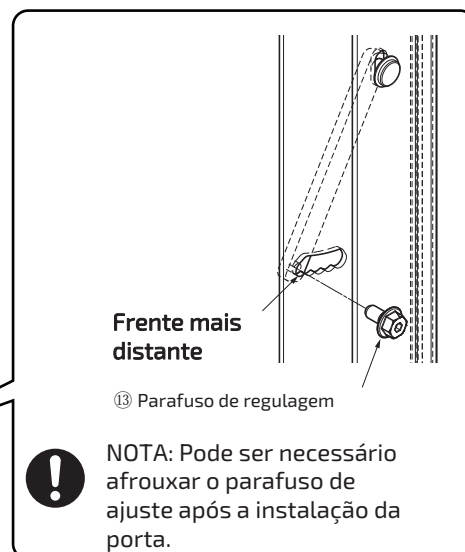
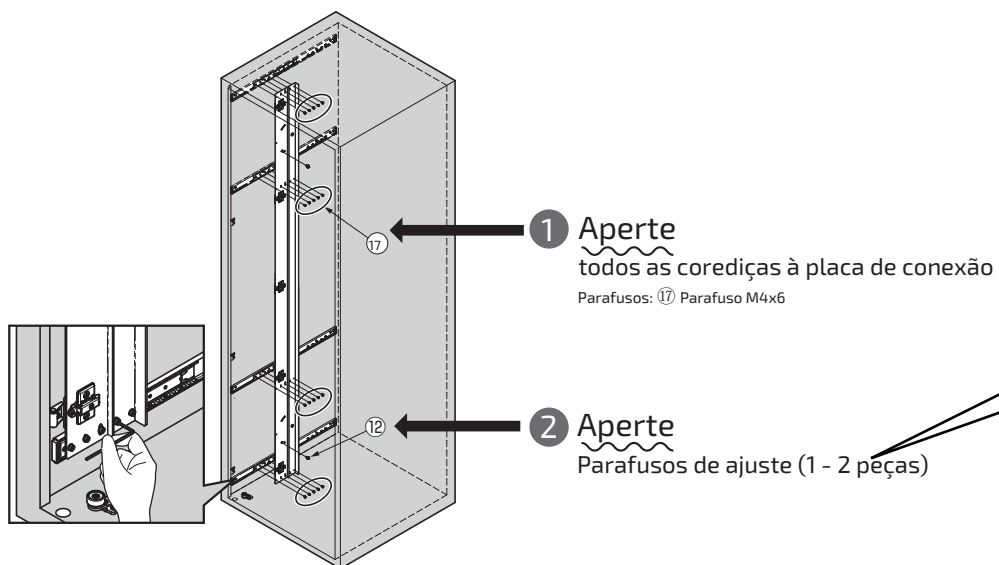

7 Fixação de todos as outras corrediças 2/2

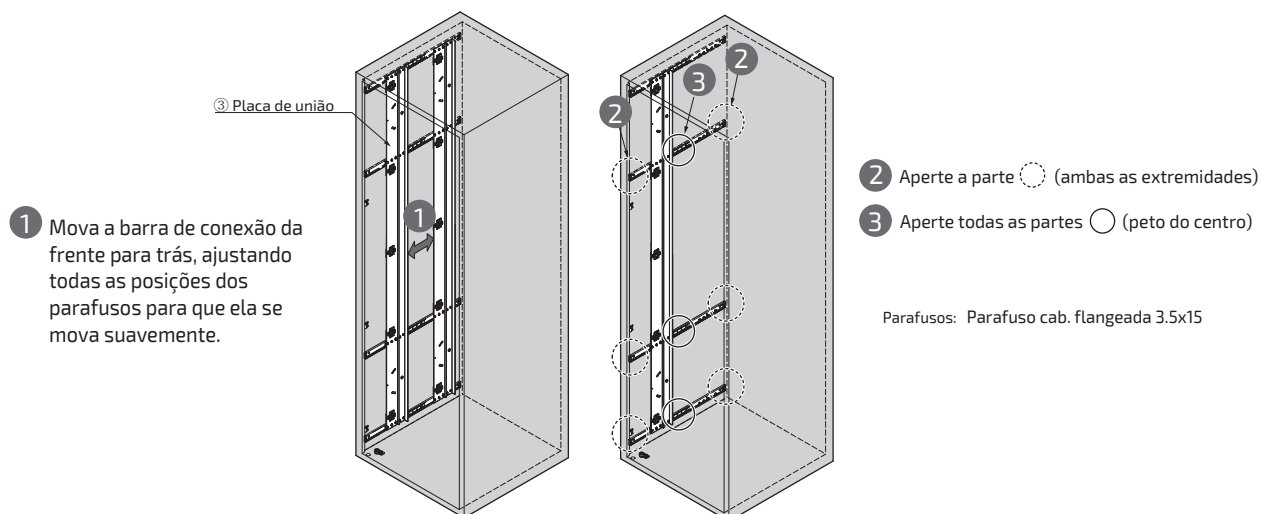

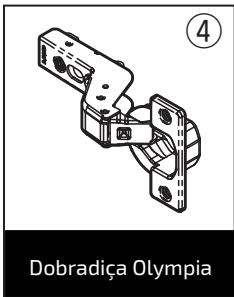

8 Instalação das dobradiças

Tipo S (2 dobradiças) Posição das dobradiças

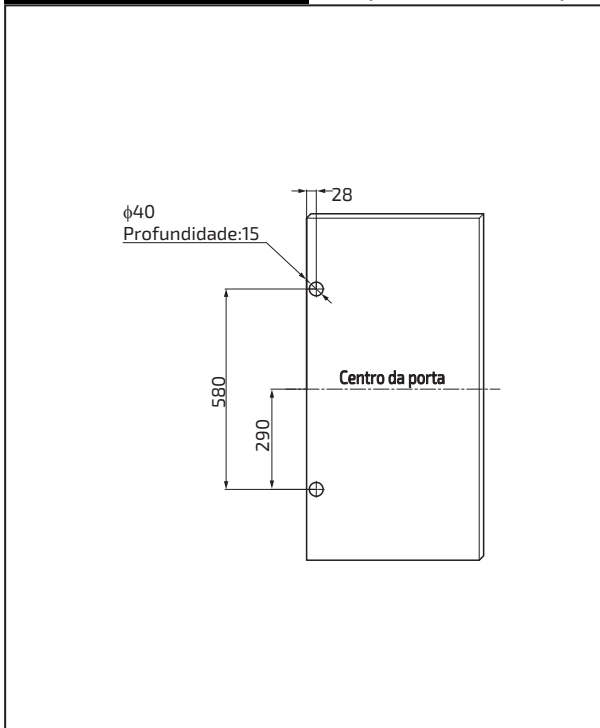

Tipo M (3 dobradiças) Posição das dobradiças

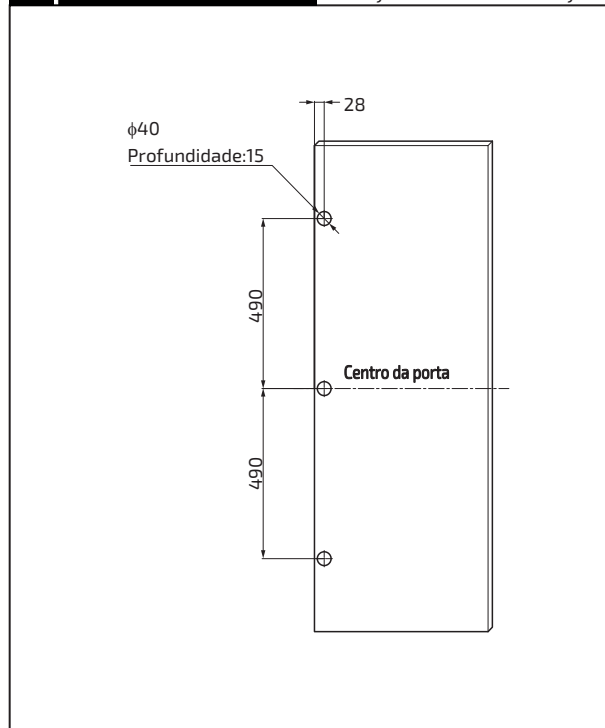

Tipo L (4 dobradiças) Posição das dobradiças

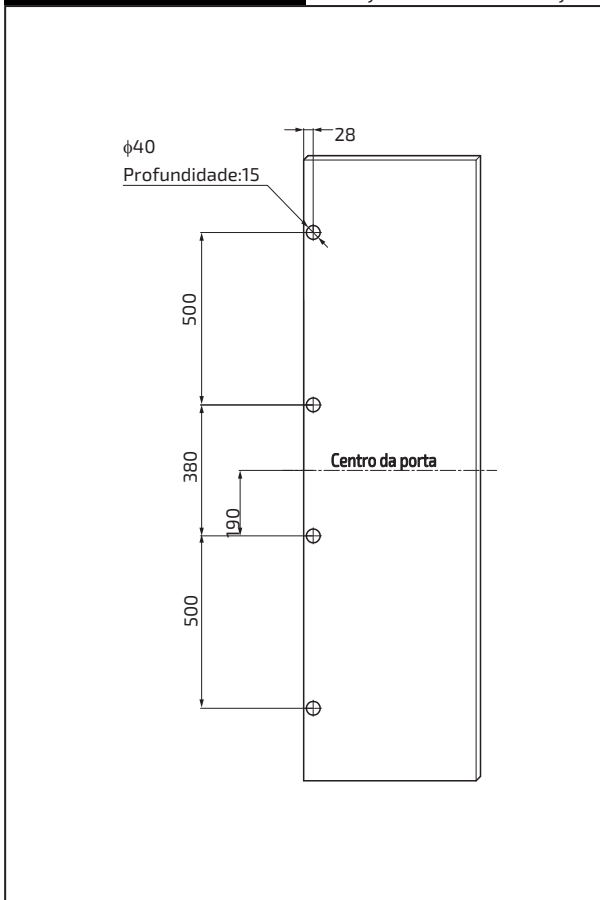

Tipo LL (5 dobradiças) Posição das dobradiças

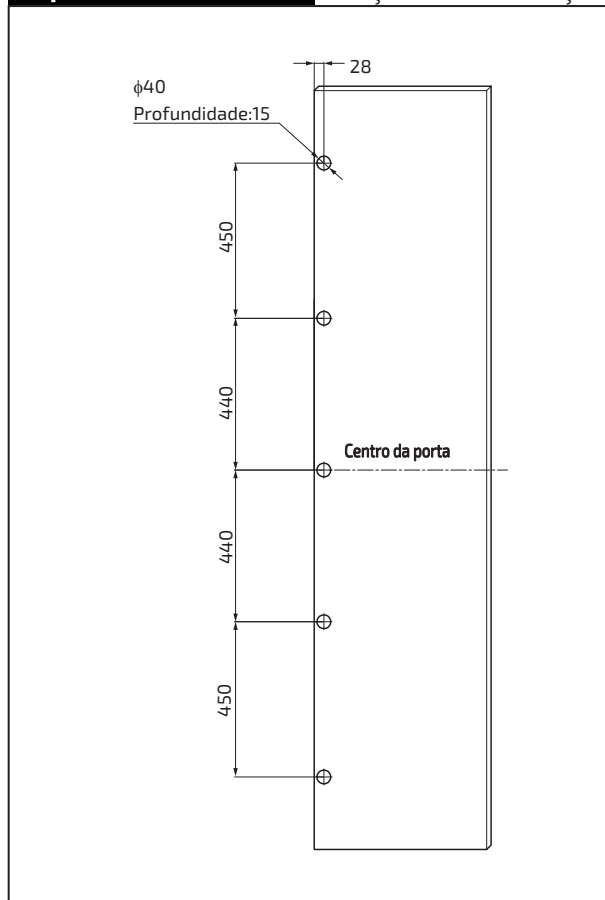

Apenas alinhe a dobradiça sobre a placa de montagem e pressione

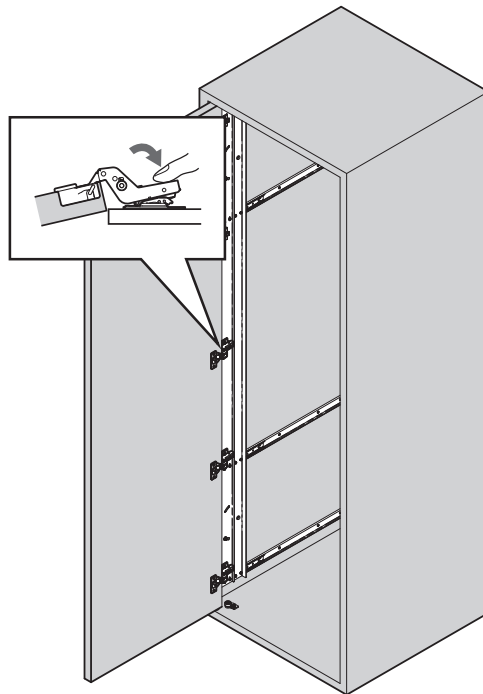

Como remover

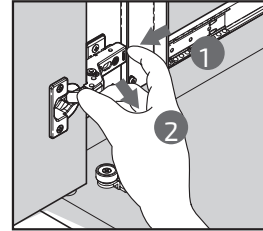

- 1 Afrouxe os parafusos que fixam a placa de conexão e os parafusos de ajuste. (Depois de apertar, afrouxe 90° - 180°)
- 2 Levante a porta e desloque o parafuso de ajuste para trás um nível de cada vez, para deixar a porta e a placa de conexão verticais. É possível um **ajuste em 5 níveis** de acordo com o peso da porta.
*Quando houver parafusos de ajuste na parte superior e inferior, alinhe suas posições.



Antes do ajuste

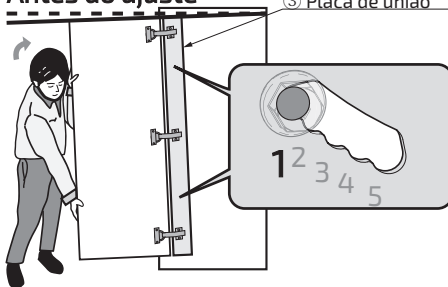

Após o ajuste

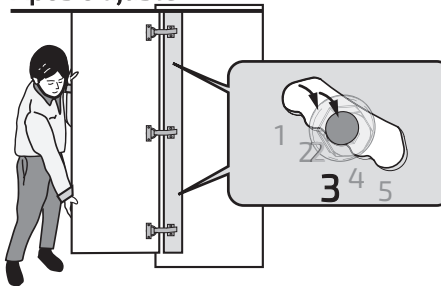

- 3 Aperte todos os parafusos provisoriamente fixados

Como regular

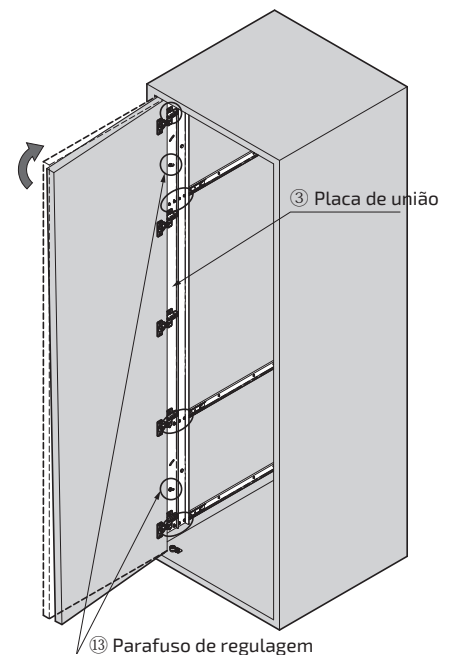



Jamais utilize uma parafusadeira para ajustes.

